

E L V E D I®

Cantilever System

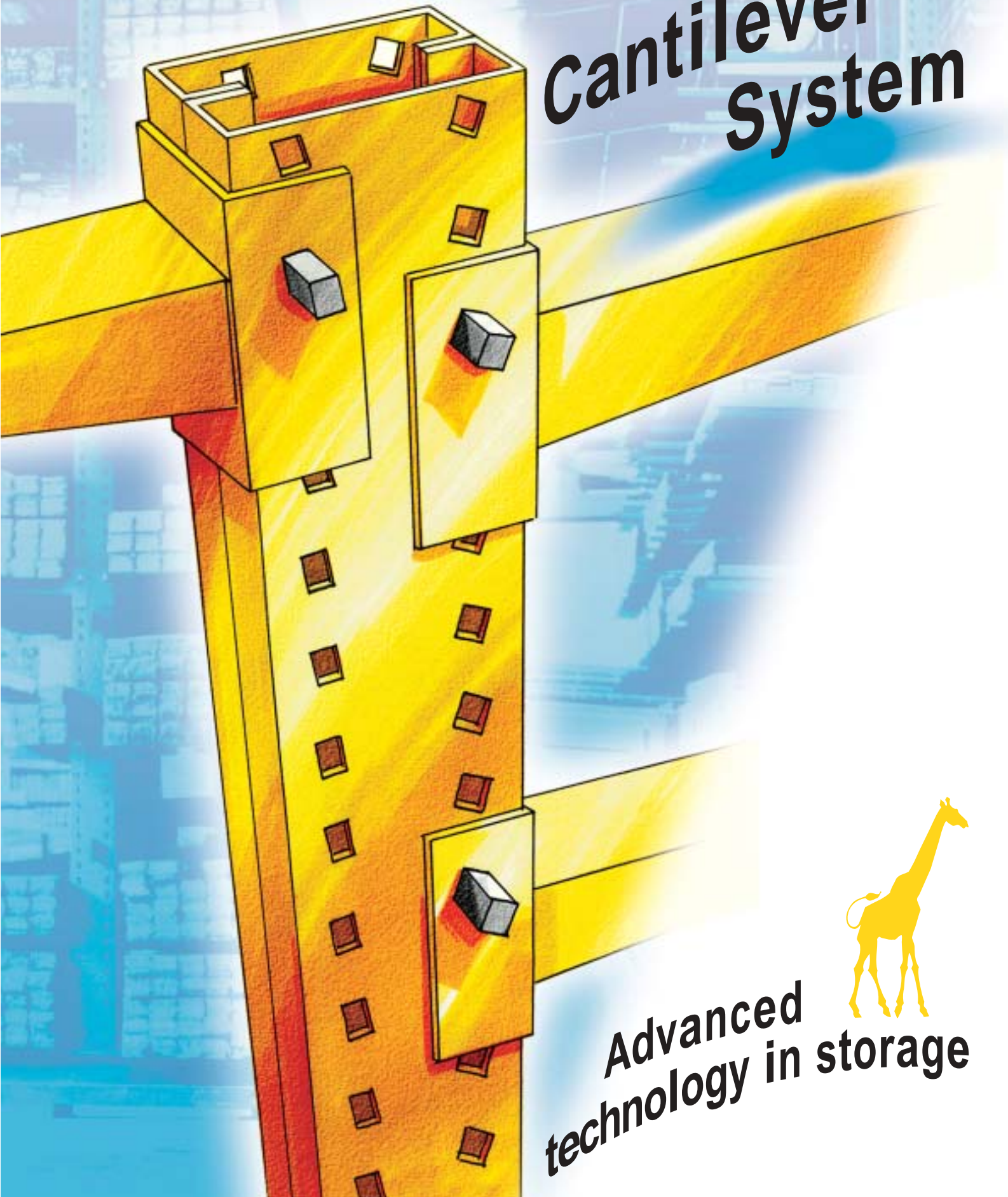

Advanced
technology in storage

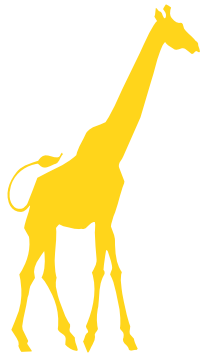

The solution for long span material

The economic system with maximum safety

Who wouldn't want an accessible and well-organised warehouse for efficient and profitable stockkeeping? The technically intelligent ELVEDI storage concept offers solutions to meet your individual needs.

Repeatedly tested (EMPA, TÜV) basic elements, columns and cantilever arms, help to ensure maximum user safety. Even under heavy duty, the ingenious structural design readily meets the most exacting requirements.

made of rigid and deflection resistant polygonal box beam sections pierced every 76 mm. Horizontal bracing is performed according to static requirements.



Cantilever arm and column are securely and easily connected by a pin of hardened steel.

Quality is binding

High-quality steel and safe static dimensioning are the unique features of Elvedi's cantilever system.

Treating and coating in backed-on epoxy polyester powder for durable protection against corrosion and surface treatment of your racking units are performed by the latest systems.

The hot dip galvanised finish ensures a robust and weatherproof outdoor use. Optimal prerequisites for lasting quality of your materials.

Long span material storage is our pet subject

The high demands placed on storage of long commodities require extensive experience. Elvedi has gained years of experience which it is putting into practice.

The robust rack columns are

Quality made of steel!



Versatility, your advantage

**You ensure storage –
we provide
the suitable
racking concept**

Elvedi's cantilever racks, the fruit of long experience, have been developed especially for professional storage of large-sized boards, metal sheets, bars, pipes, and all types of profiles. A complete programme from our own production is available to suit all your storage needs: from light to heaviest material, from simple racks to complete warehouses.

Light: SL type

For light loads. Available as standard construction from stock in three rack heights of 1920 mm / 2400 mm / 2880 mm and cantilever arms in two effective lengths of 500 mm and 700 mm.

Medium: SM type

For medium-sized loads. Supplied as standard construction in column heights of 1976 to 3952 mm and cantilever arms of 500 to 1500 mm effective length.

Heavy: HRZ type

Designed and dimensioned for heavy and heaviest loads to suit your needs and requirements. As high-rise storage equipment or as roofed and clad warehouse system.



Cantilever racking SL type



Cantilever racking SM type



Cantilever racking HRZ type



Car storage

One system, many uses



Hall construction

Satisfied customers is what counts

ELVEDI racking systems provide decisive advantages to meet the high demands on daily storage operations:

- ▶ **easy access** without re-stacking in all stored sizes saves time and money
- ▶ **logical arrangement** of the stored goods and system operation of internal materials handling
- ▶ **full use of room height** as "stored" air is too expensive!

▶ **without separating central posts** to provide horizontal "endless" storage space without sectional divisions

▶ **simple and easy stock-taking** ensures rapid inventory and control.



Pipe storage



Roofed system



Cassette storage



Mobile metal sheet storage

Benefits in daily use

Definite advantages

Height adjustment possibilities

of the cantilever arms, switching from single to double-sided use or vice versa, and simple disassembly and reassembly in other storage sites, are examples of the system's unique adaptability.

Improved operating safety

with tapered columns offer a higher visual range, especially with varying lateral loads or single-sided use. The taper compensates column deflection and precludes dangerous narrowing of the aisle width under load.

Conical cantilever arms

increase clearance height at the front end and greatly facilitate storage operations. Just think of how many times this process is repeated in practice and at what height. This is why even experienced forklift drivers do appreciate this special feature. Cantilever arms with rounded edges ensure safer storage. Compared to hot rolled profiles, they generally possess a double storage surface. The stored goods are less prone to deformation when lying flat on this larger surface area.



Large vertical clearance for comfortable storage.



Cantilever arms with rounded edges for safer storage.

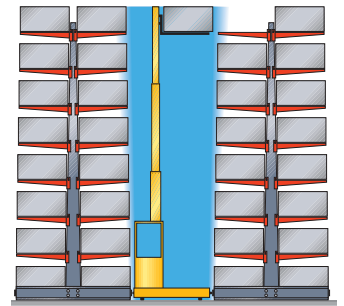

Tapered columns for higher visual range without aisle narrowing.



Column height > 20000 mm

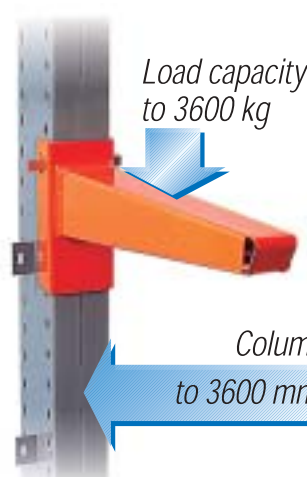

Load capacity to 3600 kg

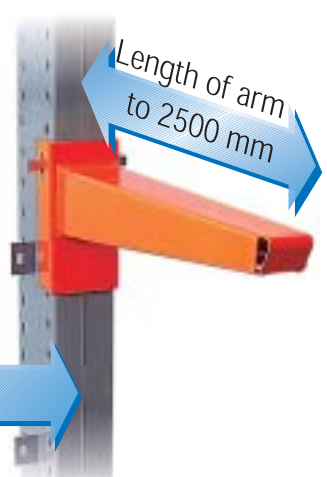

Length of arm to 2500 mm

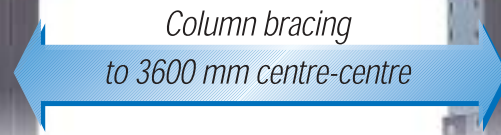

Column bracing to 3600 mm centre-centre

Dimensions and loads for ELVEDI heavy-duty cantilever racking

Practical accessories just in case



The right accessories increase efficiency and safety of your system.



Edge protection

Protects your delicate and valuable goods reliably against damage during storage operations.



Cross-beam

"Endless storage" without lateral and sectional divisions provides a significant increase in storage space.



A partner you can trust

Elvedi is one of the leading suppliers in modern storage technology owing to:

- ▶ highly motivated and qualified staff
- ▶ a creative development department with many innovative production concepts
- ▶ the latest computer controlled production
- ▶ consulting and sales presence in all the important markets
- ▶ availability of complete and own storage technology: from different rack units to multi-storey systems and storage warehouses.



Endstopper

Prevents stored goods from dropping out, particularly round material, and contributes to increasing operating safety.



Guide rails

Minimal aisle widths in combination with rail-driven forklift trucks.



Crusher zone

Effective ramming protection against inadvertent forklift collision with the rack base. The forces of impact are resiliently absorbed and damages to rack and stored goods precluded.

ELVEDI®



**Advanced
technology in storage**

(CH) Elvedi AG
Bahnstrasse 23
CH-8603 Schwerzenbach
Tel. 01/826 70 00
Fax 01/826 70 01

(D) Elvedi GmbH
Aitlingerstrasse 18
Riedöschingen
D-78176 Blumberg
Tel. 0 77 02/ 43 82-0
Fax 0 77 02/ 43 82-10

(A) Elvedi Ges.m.b.H.
Kalvariengürtel 67/III
A-8020 Graz
Tel. 03 16/ 67 10 26
Fax 03 16/ 67 10 26-12

(F) ELVEDI System
210 Rue Pierre
et Marie Curie
F-76650 Petit Couronne
Tel. 02 35 69 23 23
Fax 02 35 69 14 64

(B) Elvedi Belgien
Michel De Backer
Jozef Hermanslei 78
B-2640 Mortsel
Tel. 03 449 68 01
Fax 03 449 68 30

(H) Elvedi Hungaria Kft.
Nagymező u.4.
H-1065 Budapest
Tel. 01 352 7164
Fax 01 352 7164

Please contact our swiss office for name and address of the nearest agency.

www.elvedi.com

e-mail: info@elvedi.com